

TOP VIEW

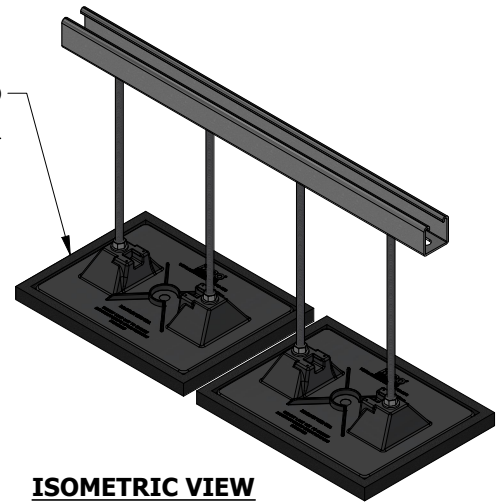

ISOMETRIC VIEW

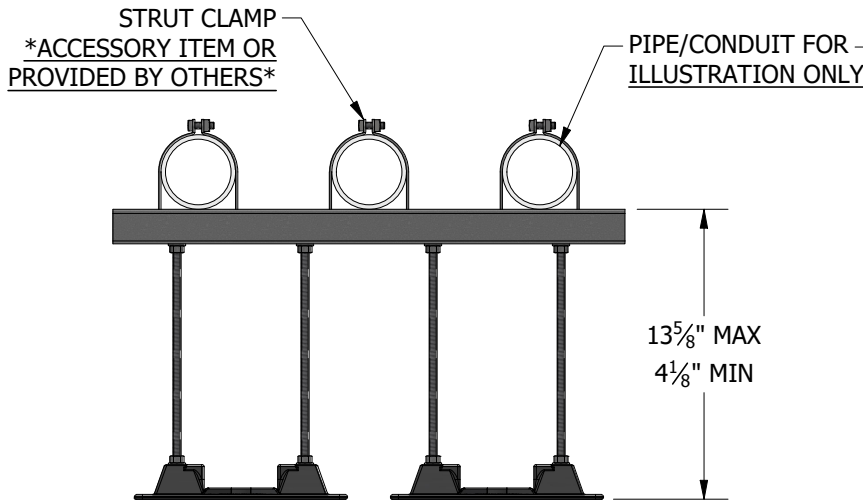

END VIEW



SIDE VIEW

ACCESSORIES

- Strut Clamp - Order to Pipe O.D.
- (2) 7 1/2" x 10" Support pads
- Eternabond® 2-sided tape

PRODUCT DESCRIPTION

A pipe support with "strut" used to support roof-mounted electrical conduit, solar piping, gas pipes and other mechanical piping. Pipes rest on a 24" length of strut which is mounted on the bases. The pipes can be fastened by using the appropriate pipe clamp.

KEY INFORMATION

- Designed to support conduit (ganged) cable trays or other mechanical piping.
- Adjustable from the factory set maximum height of 13-5/8" down to a minimum height of 4-1/8"
- Maximum load is 172.5 lbs/ft. (3.0 psi) Make certain each support is properly elevated to evenly distribute weight at all support locations.
- Unit Weight: 7.04 lbs.
- Recommended spacing is not to exceed 10' centers depending upon the load.

MATERIAL INFORMATION

- Base Material: Polycarbonate
- 3/8"-16 304 SS All-Thread
- 1-5/8"x1-5/8" 12 ga. HDG slotted strut
- HDG hardware