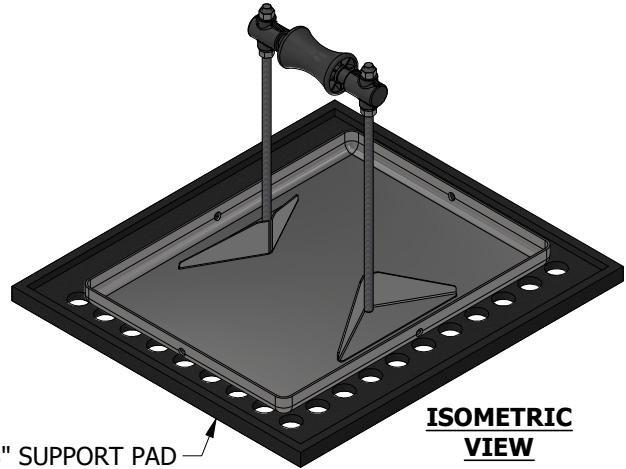
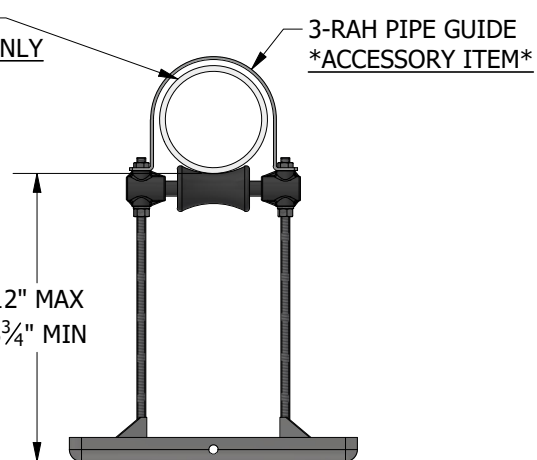
**TOP VIEW****ISOMETRIC VIEW**

16" x 18" SUPPORT PAD  
\*ACCESSORY ITEM\*

**SIDE VIEW**

4" SCH. 40 PIPE  
ILLUSTRATION ONLY

**FRONT VIEW**

3-RAH PIPE GUIDE  
\*ACCESSORY ITEM\*

12" MAX  
3 3/4" MIN

**ACCESSORIES**

- Refer to 4-RAH Pipe Guide specification for available sizes.
- 16" x 18" Support pad
- Eternabond® 2-sided tape

**PRODUCT DESCRIPTION**

A "roller-bearing" pipe support used to support roof-mounted gas pipes, electrical conduit, solar piping and other mechanical piping. Unique design absorbs thermal expansion and contraction of pipes thus preventing damage to the roof membrane. Pipes rest on a self-lubricating polycarbonate resin axle and roller.

**KEY INFORMATION**

- Optimally designed for a 4" pipe.
- Maximum pipe OD (with insulation) is 5-1/2".
- Adjustable from the factory set maximum height of 12" down to a minimum height of 3-3/4".
- Maximum load is 186 lbs. (All-thread capacity) Make certain each pipe support is properly elevated to evenly distribute weight at all pipe support locations.
- Unit weight: 8.32 lbs.
- Recommended spacing is not to exceed 10' centers depending upon the load.

**MATERIAL INFORMATION**

- Base Material: 16 ga. 304 SS
- All-thread: 3/8"-16 SS
- Roller, Axle and Collar Material: Polycarbonate
- Hardware: HDG