

TOP VIEW

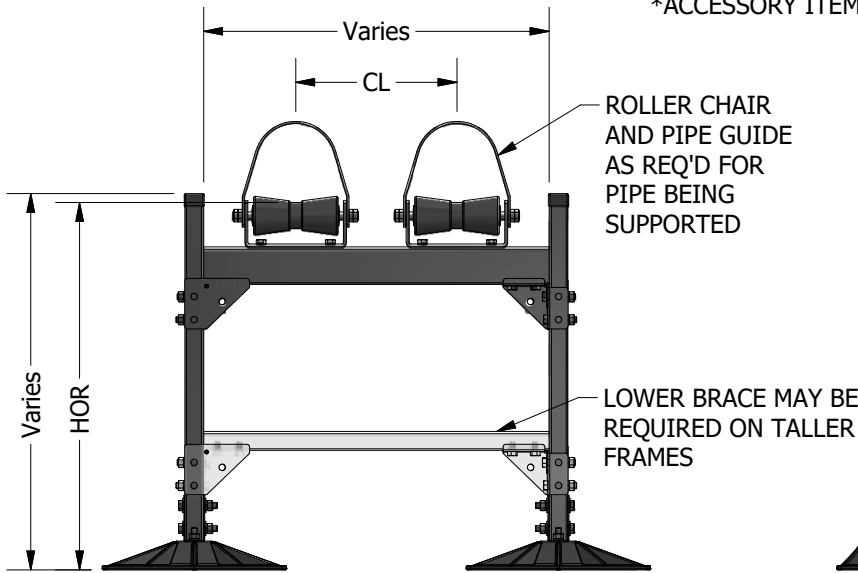

ISOMETRIC VIEW



FRONT VIEW

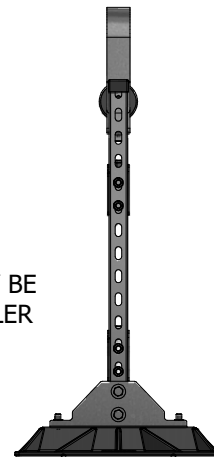

SIDE VIEW

ACCESSORIES

- 16 x 18 Support pad
- Cross bracing

PRODUCT DESCRIPTION

Pipe supports for multiple pipes at various heights. To obtain pricing for the 8H model, call your local representative and have the following information available:

1. Specify quantity of supports needed or provide a rooftop pipe layout drawing and MIRO Ind. will provide a quote with a support layout drawing.
2. Type of pipe being supported (Sch. 40 Steel)
3. Pipe sizes (trade size)
4. Pipe content (liquid or gas)
5. Centerline distance between pipes (CL)
6. Height off roof (HOR)
7. Pipe insulation thickness.

KEY INFORMATION

- The 8H series support is designed and engineered to project specific requirements provided to MIRO Industries.
- Maximum loading from any MIRO base to the finished roof surface is not to exceed 3.0 psi (578 lbs/base) unless specifically allowed otherwise in the project specification.
- Deflection in the horizontal header bar is not to exceed the span length by 360 or 1/8".
- Frame is designed for gravity loading only.
- Recommended horizontal support spacing is not to exceed 10 feet centers or as required by the applicable design code or project specifications.
- Contractor is to ensure each pipestand is properly elevated to evenly distribute loading at all pipestands.
- Frame is made with 12 ga slotted strut; Support legs are 1-5/8"x1-5/8" and header bar is either 1-5/8" x 1-5/8" or 1-5/8"x3-1/4".
- Base material is polycarbonate
- All metal parts are hot dip galvanized

The information contained in this drawing is the sole property of MIRO Industries, Inc. Any reproduction in part or as a whole without written permission of MIRO Industries, Inc. is prohibited.

DATE:

JAN 2019

8H-(#)RC P