

**TOP VIEW**

19x23 SUPPORT PAD  
\*ACCESSORY ITEM)

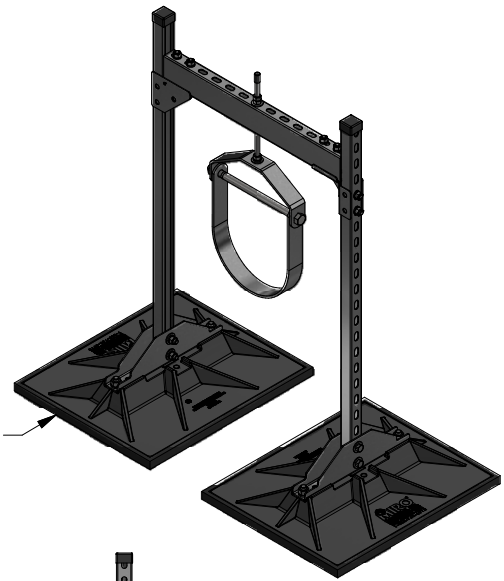

**ISOMETRIC VIEW**

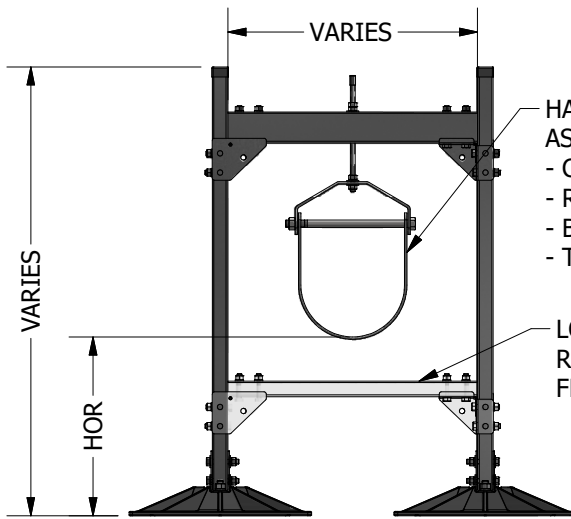

**FRONT VIEW**



**SIDE VIEW**

**ACCESSORIES**

- 19 x 23 Support pad
- Cross bracing

**PRODUCT DESCRIPTION**

Pipe supports for a single pipe at various heights. To obtain pricing for the 10H model, call your local representative and have the following information available:

1. Specify quantity of supports needed or provide a rooftop pipe layout drawing and MIRO Ind. will provide a quote with a support layout drawing.
2. Type of pipe being supported (Sch. 40 Steel)
3. Pipe sizes (trade size)
4. Pipe content (liquid or gas)
5. Centerline distance between pipes (CL)
6. Height off roof (HOR)
7. Pipe insulation thickness.
8. Preferred hanger type (Clevis, Roller, Band or Trapeze)

**KEY INFORMATION**

- The 10H series support is designed and engineered to project specific requirements provided to MIRO Industries.
- Maximum loading from any MIRO base to the finished roof surface is not to exceed 3.0 psi (960 lbs/base) unless specifically allowed otherwise in the project specification.
- Deflection in the horizontal header bar is not to exceed the span length by 360 or 1/8".
- Frame is designed for dead load only.
- Recommended horizontal support spacing is not to exceed 10 feet centers or as required by the applicable design code or project specifications.
- Contractor is to ensure each pipestand is properly elevated to evenly distribute loading at all pipestands.
- Frame is made with 12 ga slotted strut; Support legs are 1-5/8"x1-5/8" and header bar is either 1-5/8" x 1-5/8" or 1-5/8"x3-1/4".
- Base material is polycarbonate
- All metal parts are hot dip galvanized