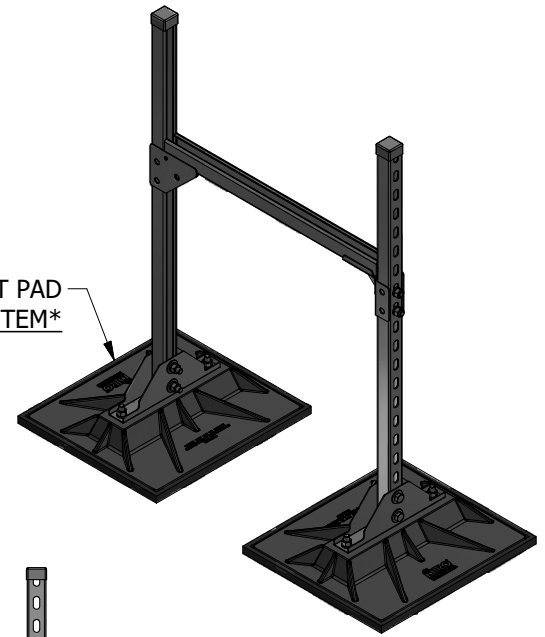
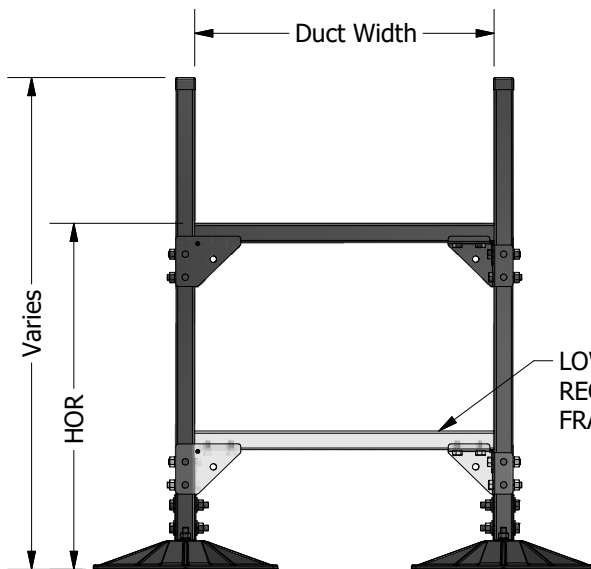
**Top View**

16x18 SUPPORT PAD
ACCESSORY ITEM

**Isometric View****Front View**

LOWER BRACE MAY BE
REQUIRED ON TALLER
FRAMES

**Side View****ACCESSORIES**

- 16 x 18 Support pad
- Cross bracing

PRODUCT DESCRIPTION

Duct and Cable Trays are designed for single or multiple duct supports and cable trays.

To obtain pricing for the 8DS model, call your local representative and have the following information available:

1. Specify number of supports needed or provide a roof top duct layout drawing and MIRO Ind. will provide a support layout drawing and take off.
2. Dimensions of duct (Width x Height, or Diam)
3. Duct material (gauge thickness)
4. Clearance height above roof (HOR)
5. Exterior insulation thickness (if any)
6. Does duct need to be enclosed?

KEY INFORMATION

- The 8DS series support is engineered to ensure member/component capacities and deflection criteria are not exceeded.
- Maximum loading from any MIRO base to the finished roof surface is not to exceed 3.0 psi (578 lbs/base) unless specifically allowed otherwise in the project specifications.
- Deflection in the horizontal header bar is not to exceed the span length by 360 or 1/8".
- Frame is designed for gravity loading only.
- Recommended spacing is not to exceed 8 feet centers depending upon the load.
- Width and height are built job specific based on information provided to MIRO Ind. with a minimum height of 12".
- Frame is made with 12 Gauge Channel; size is determined during design.
- Base Material: Polycarbonate
- All metal parts are hot dip galvanized