

TOP VIEW

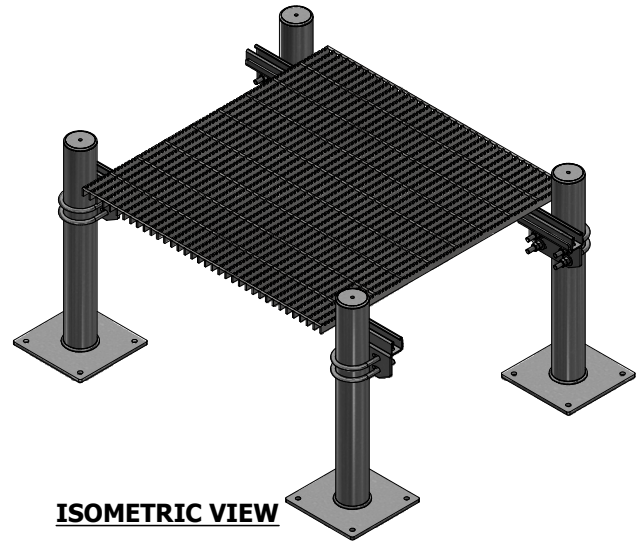

ISOMETRIC VIEW

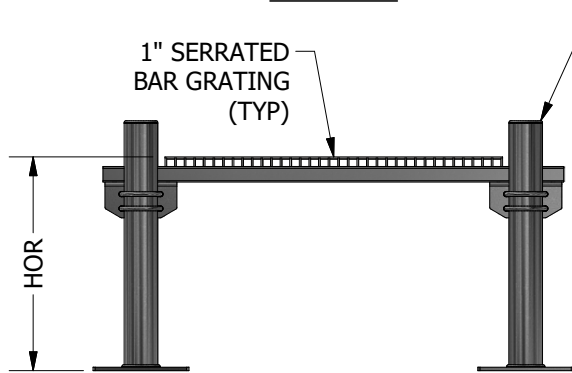

SIDE VIEW

FRAME, BASE PLATE AND ANCHORAGE TO BE DESIGNED TO MEET PROJECT SPECIFIC REQUIREMENTS

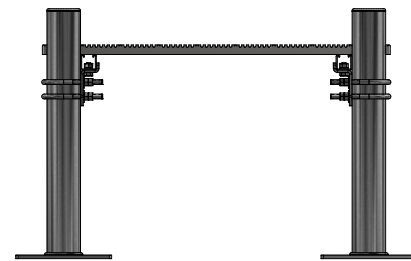

END VIEW

PRODUCT DESCRIPTION

MIRO Stanchioned HD Mechanical Supports are custom designed in-house to meet project specific needs and code requirements. Bases and material are selected to meet design constraints and specifications.

Positive attachment to the building structure is required to resist minimum lateral and uplift loading requirements per code requirements.

The project engineer of record is responsible for the design of the building structure and local reinforcement where required to withstand applied load.

KEY INFORMATION

Information needed to complete the design:

- Project Address
- Structural Drawings if available
- Design Criteria (typically available in the Structural General Notes)
- If structural drawings are not available a MIRO Design Professional can assist with obtaining the required information.
- Description of the intended use of the building
- Average Roof Height or elevation where equipment is being supported
- Cross-section view of roof construction
- All metal parts are either stainless steel or hot-dip galvanized.