

**TOP VIEW**

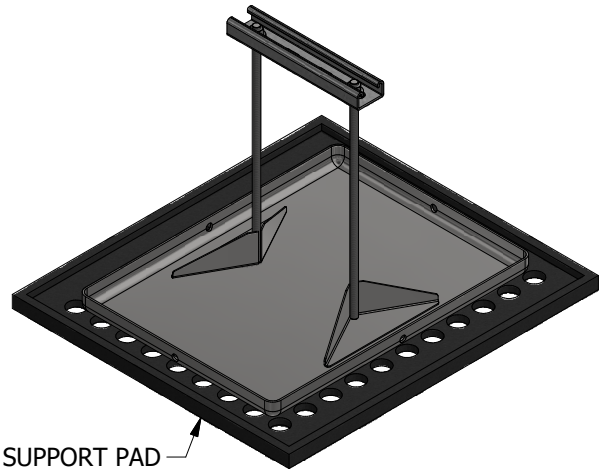

16" x 18" SUPPORT PAD  
\*ACCESSORY ITEM\*

**ISOMETRIC VIEW**

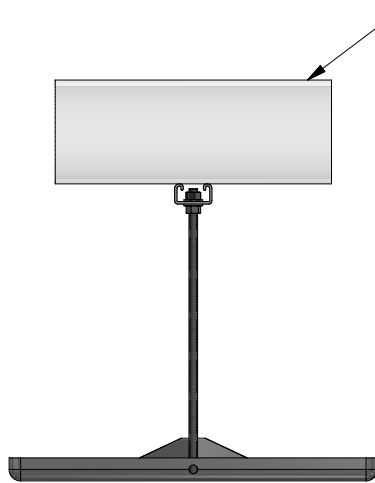

**SIDE VIEW**

4" SCH. 40 PIPE  
ILLUSTRATION ONLY

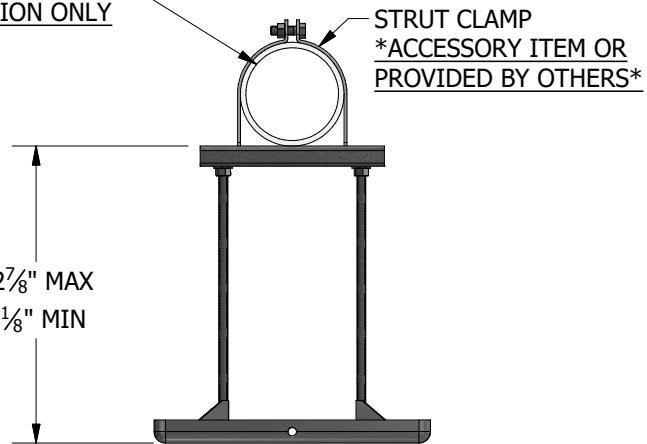

**END VIEW**

STRUT CLAMP  
\*ACCESSORY ITEM OR PROVIDED BY OTHERS\*

12<sup>7</sup>/<sub>8</sub>" MAX  
3<sup>1</sup>/<sub>8</sub>" MIN

**ACCESSORIES**

- Strut Clamp - Order to Pipe O.D.
- 16" x 18" Support pad
- Eternabond® 2-sided tape

**PRODUCT DESCRIPTION**

A pipe support with "strut" used to support roof-mounted electrical conduit, solar piping, gas pipes and other mechanical piping. Pipes rest on a 12" length of strut which is mounted on the base. The pipes can be fastened by using the appropriate pipe clamp.

**KEY INFORMATION**

- Designed to support conduit (ganged) cable trays or other mechanical piping.
- Adjustable from the factory set maximum height of 12-7/8" down to a minimum height of 3-1/8"
- Maximum load is 186 lbs. (All-thread capacity) Make certain each support is properly elevated to evenly distribute weight at all support locations.
- Unit Weight: 8.93 lbs.
- Recommended spacing is not to exceed 10' centers depending upon the load.
- Base Material: Stainless steel
- All metal parts are either stainless steel or hot-dip galvanized.