

TOP VIEW

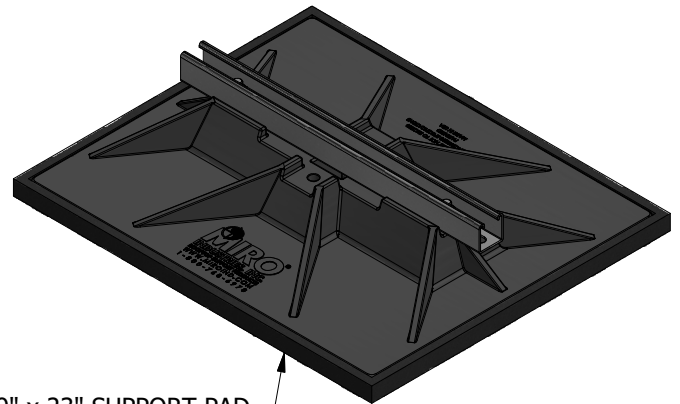

19" x 23" SUPPORT PAD
ACCESSORY ITEM

ISOMETRIC VIEW

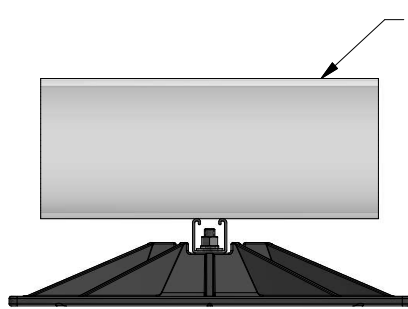

SIDE VIEW

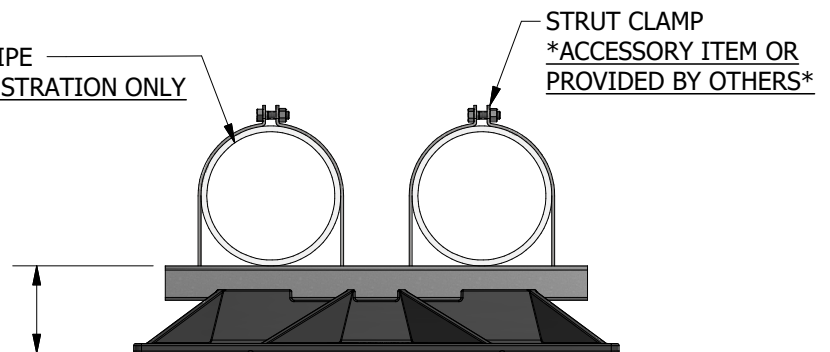

END VIEW

ACCESSORIES

- Strut Clamp - Order to Pipe O.D.
- 19" x 23" Support pad
- Eternabond® 2-sided tape

PRODUCT DESCRIPTION

A pipe support with "strut" used to support roof-mounted electrical conduit, solar piping, gas pipes and other mechanical piping. Pipes rest on a 20" length of strut which is mounted on the base. The pipes can be fastened by using the appropriate pipe clamp.

KEY INFORMATION

- Designed to support conduit (ganged) cable trays or other mechanical piping.
- Fixed height at 4-1/8"
- Maximum load is 960 lbs. (3.0 psi) Make certain each support is properly elevated to evenly distribute weight at all support locations.
- Unit Weight: 11.02 lbs.
- Recommended spacing is not to exceed 10' centers depending upon the load.
- Base Material: Polycarbonate
- All metal parts are either stainless steel or hot-dip galvanized.