

19" x 23" SUPPORT PAD
ACCESSORY ITEM

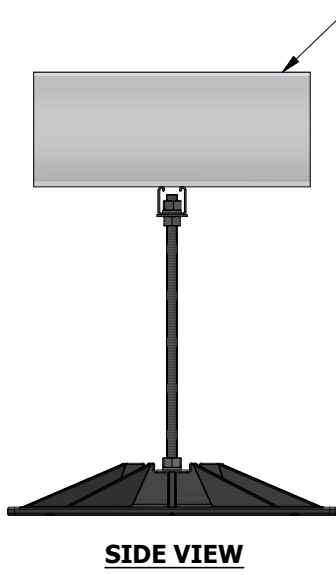

PIPE/CONDUIT FOR ILLUSTRATION ONLY

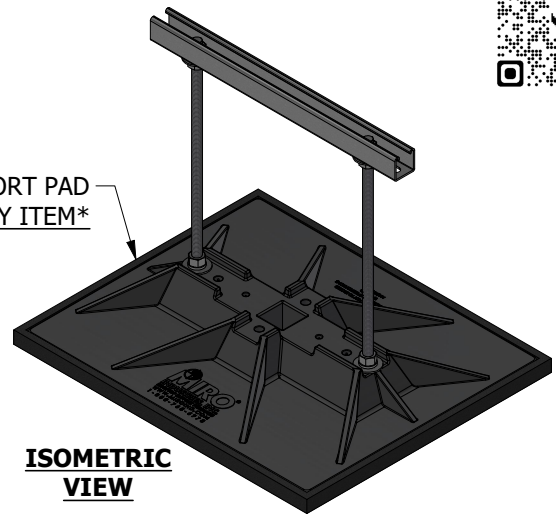
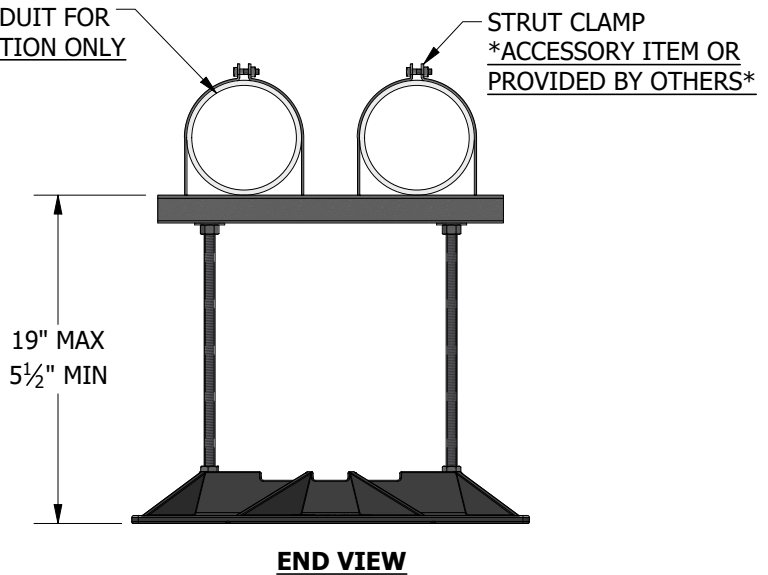

STRUT CLAMP
ACCESSORY ITEM OR PROVIDED BY OTHERS

19" MAX
5 1/2" MIN

ACCESSORIES

- Strut Clamp - Order to Pipe O.D.
- 19" x 23" Support pad
- Eternabond® 2-sided tape

PRODUCT DESCRIPTION

A pipe support with "strut" used to support roof-mounted electrical conduit, solar piping, gas pipes and other mechanical piping. Pipes rest on a 20" length of strut which is mounted on the base. The pipes can be fastened by using the appropriate pipe clamp.

KEY INFORMATION

- Designed to support conduit (ganged) cable trays or other mechanical piping.
- Adjustable from the factory set maximum height of 19" down to a minimum height of 5-1/2"
- Maximum load is 717 lbs. (All-thread capacity) Make certain each support is properly elevated to evenly distribute weight at all support locations.
- Unit Weight: 16.74 lbs.
- Recommended spacing is not to exceed 10' centers depending upon the load.

MATERIAL INFORMATION

- Base Material: Polycarbonate
- 5/8"-11 304 SS All-Thread
- 1-5/8"x1-5/8" 12 ga. HDG slotted strut
- HDG hardware

The information contained in this drawing is the sole property of MIRO Industries, Inc. Any reproduction in part or as a whole without written permission of MIRO Industries, Inc. is prohibited.

DATE:
JAN 2022

20-BASE STRUT-18