

TOP VIEW

16" x 18" SUPPORT PAD
ACCESSORY ITEM

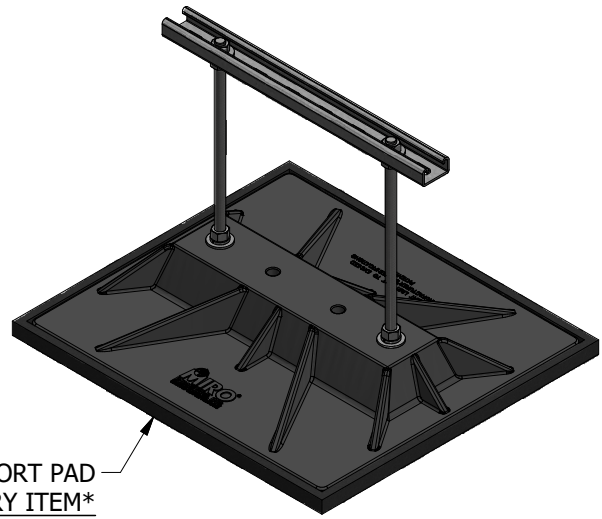

ISOMETRIC VIEW



SIDE VIEW

3" PIPE
ILLUSTRATION ONLY

STRUT CLAMP
ACCESSORY ITEM OR PROVIDED BY OTHERS

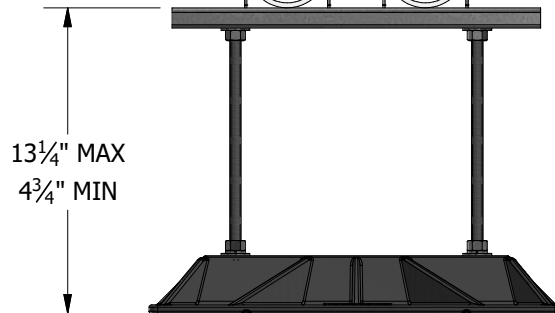

END VIEW

13 1/4" MAX
4 3/4" MIN

ACCESSORIES

- Strut Clamp - Order to Pipe O.D.
- 16" x 18" Support pad
- Eternabond® 2-sided tape

PRODUCT DESCRIPTION

A pipe support with "strut" used to support roof-mounted electrical conduit, solar piping, gas pipes and other mechanical piping. Pipes rest on a 16" length of strut which is mounted on the base. The pipes can be fastened by using the appropriate pipe clamp.

KEY INFORMATION

- Designed to support conduit (ganged) cable trays or other mechanical piping.
- Adjustable from the factory set maximum height of 13-1/4" down to a minimum height of 4-3/4"
- Maximum load is 578 lbs. (3.0 psi) Make certain each support is properly elevated to evenly distribute weight at all support locations.
- Unit Weight: 7.90 lbs.
- 4 per case, 36 lbs. per case, (DW= 71 lbs.)
- Recommended spacing is not to exceed 10' centers depending upon the load.
- Base Material: Polycarbonate
- All metal parts are either stainless steel or hot-dip galvanized.