

TOP VIEW

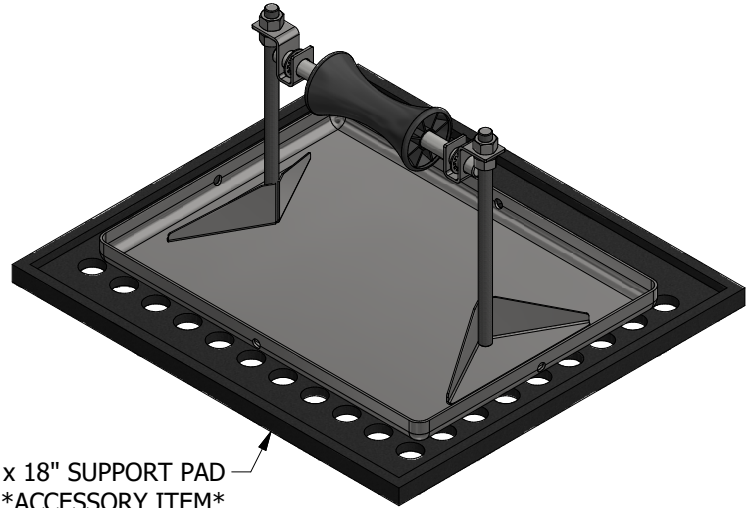

16" x 18" SUPPORT PAD
ACCESSORY ITEM

ISOMETRIC VIEW

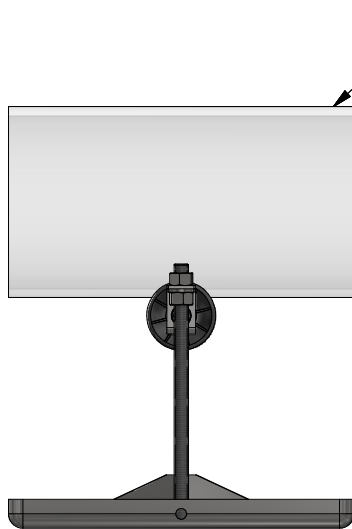

SIDE VIEW

6" SCH. 40 PIPE
ILLUSTRATION ONLY

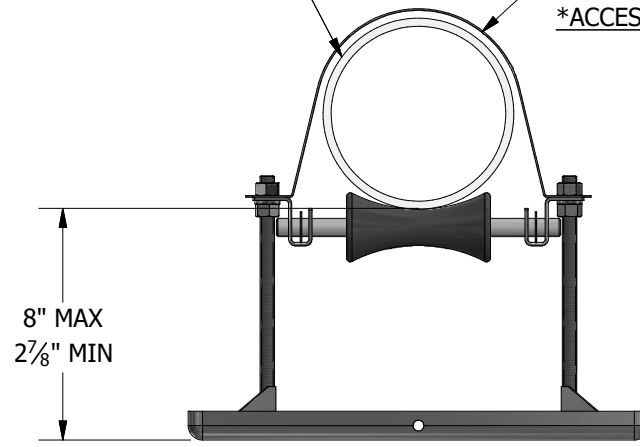

6-RAH PIPE GUIDE
ACCESSORY ITEM

8" MAX
2 7/8" MIN

FRONT VIEW

ACCESSORIES

- Refer to 6-RAH Pipe Guide specification for available sizes.
- 16" x 18" Support pad
- Eternabond® 2-sided tape

PRODUCT DESCRIPTION

A "roller-bearing" pipe support used to support roof-mounted gas pipes, electrical conduit, solar piping and other mechanical piping. Unique design absorbs thermal expansion and contraction of pipes thus preventing damage to the roof membrane. Pipes rest on a self-lubricating polycarbonate resin axle and roller.

KEY INFORMATION

- Optimally designed for a 6" pipe.
- Maximum pipe OD (with insulation) is 8-1/2".
- Adjustable from the factory set maximum height of 8" down to a minimum height of 2-7/8".
- Maximum load is 524 lbs. (3.0 psi) Make certain each pipe support is properly elevated to evenly distribute weight at all pipe support locations.
- Unit weight: 9.74 lbs.
- Recommended spacing is not to exceed 10' centers depending upon the load.
- Base Material: Stainless Steel
- Roller Material: Polycarbonate
- 1/2" all-thread and 5/8" axle are stainless steel
- All other metal parts are hot-dip galvanized

The information contained in this drawing is the sole property of MIRO Industries, Inc. Any reproduction in part or as a whole without written permission of MIRO Industries, Inc. is prohibited.

DATE:
JAN 2019

6-RAH-8 SS