

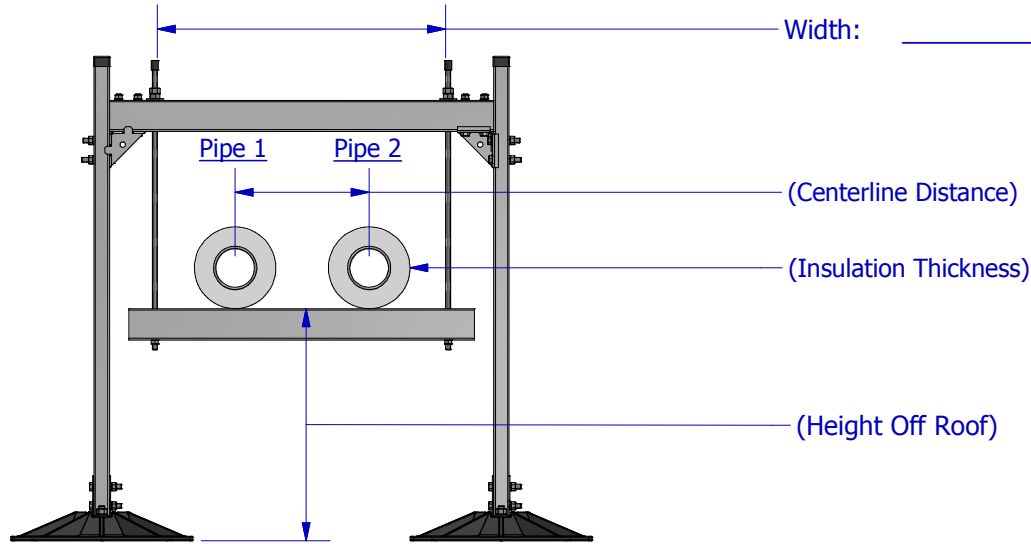

TRAPEZE QUOTE TEMPLATE

Job Name: _____



-	Pipe 1	Pipe 2	Pipe 3	Pipe 4
Pipe Size				
Insulation Thickness				
Pipe Type				
Pipe Contents				
Height Off Roof				
Centerline Distance				

Number of Supports: _____

Frame Label: _____

ACCESSORIES

- Support pad
- Cross bracing

KEY INFORMATION

- Trapeze supports are engineered to ensure member/component capacities and deflection criteria are not exceeded. Maximum loading from any MIRO base to the finished roof surface is not to exceed 2.0 psi unless specifically allowed otherwise in the project specification. Deflection in the horizontal header bar is not to exceed the span length by 360 or 1/8.
- Trapeze supports and its related configurations allow adjustable height as desired or required by the code or roof system. Cross-bracing two adjacent pipe stands is required for elevations of 36" and higher. Purchasers must specify desired heights and multiple pipe centerline spacing upon quote requests and ordering of 10-H series stands.
- Recommended spacing is not to exceed 10 feet centers depending upon the load. Make certain each pipestand is properly elevated to even loadweight at all pipestands.
- Width and height are built job specific based on information provided to MIRO Ind.
- Frame is made with 12 Gauge Channel; size is determined during design
- Base Material: Polycarbonate
- All metal parts are hot dip galvanized

This document, attachments, and all of the information therein are the property of MIRO Industries, Inc. The information contained is loaned, subject to return upon demand, and is not to be used directly or indirectly in any way detrimental to our interest. Further the information contained therein shall not be used, in whole or in part, except when allowed by written authorization from MIRO Industries, Inc. © MIRO INDUSTRIES, INC. 2003-2014